

## Replacing Filter

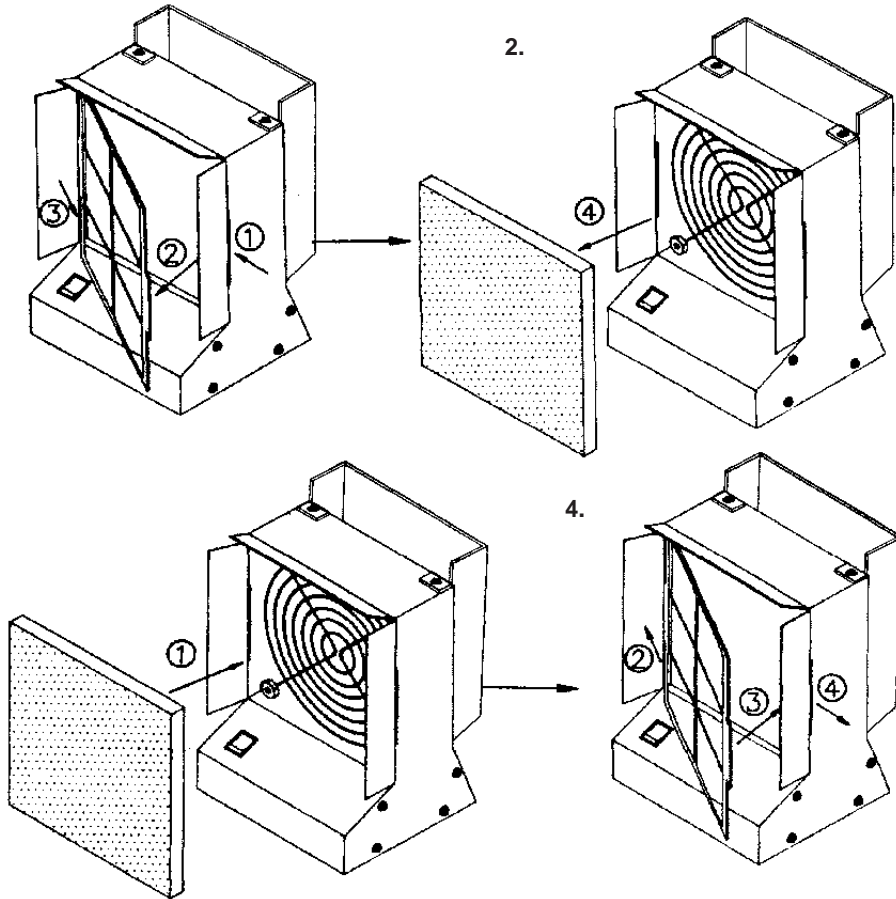

### Care & Maintenance Notice

- Before use, always check the barrel locking nut is hand-tightened to ensure the tip is firmly held in position.
- Regularly remove the barrel and tip to keep it clean and clear of debris. This should be done at least once a week.
- The element is of ceramic composition which is sensitive to sharp or strong impact. **Do not** drop it, or 'tap' the soldering iron in an effort to clean it. Cleaning should always be performed with a damp sponge while the tip is hot.

**Failure to Comply Will Void Warranty**

Altronic Distributors Pty. Ltd. 174 Roe St, Perth W.A. 6000

Phone: (08) 9428 2199 Fax: (08) 9428 2198



*T 2444 Soldering Station with Fume Extractor*

## Operating Instructions



- Continuously variable temperature control
- Zero switching circuitry for spike suppression
  - High idle stability
  - Fast heat recovery

## Product Description

The Micron T 2444 Temperature Controlled Soldering Station with Fume Extractor has been developed to meet the present and future needs of the electronic production industry. It incorporates electronic circuitry which enables the user to change the tip temperature from 250°C through 430°C without changing the tip or heating element. The transformer-less power supply ensures excellent temperature stability by accurately monitoring the minute changes in element resistance which occur in proportion to temperature variations. The electronic opto isolated "zero voltage" switching used protects voltage and current sensitive components, such as CMOS devices, against transient voltage spikes, which can be caused by switching the power or heater on/off, or other environmental conditions. The ceramic heating element is designed specially to bring the element temperature up to approximately 565°C at full setting in under one minute. The higher temperature allows for reserve heat to ensure ultra fast recovery at lower temperature settings. The high insulation of the ceramic heating element is over 100M ohm and the tip is grounded to ensure leakage is less than 0.4 millivolts.

## Operating instructions

- 1 Seat the iron into the stand provided.
- 2 Plug in the power cable and slide the switch to 'on' position then LED lamp will be on.
- 3 Set temperature by rotating temperature control knob on the front panel to the temperature desired.
- 4 Always keep the sponge wet.
- 5 Set the temperature control knob to the minimum when temporarily not using the soldering station, thereby extending the life of heater and tip.

## Working Temperature

A low iron temperature will slow the flow of solder. A high temperature will burn the flux in the solder, which in turn will emit a heavy white smoke, that can result in a dry joint or damage to the PCB. When the tip working temperature is within the correct parameters suited to the particular solder being used, a good joint is assured. The most common solder alloy used in the electronics industry is 60% tin, 40% lead (60/40). The tip working temperature of solder is detailed below and can vary slightly from manufacturer to manufacturer.

Melting point .....	215°C
Normal Operation.....	320°C
Production Line Operation .....	380°C
Desoldering Operation for Small Joint.....	320°C
Desoldering Operation for Larger Joint.....	400°C

*Caution: Temperatures above 400°C should not be used for normal soldering purposes; however temperatures above 400°C may be used for short periods when required.*

## Possible causes of tip not tinning

- 1 Tip temperature higher than 400°C
- 2 Working surface is not well tinned during idling periods
- 3 Lack of flux in soldering, wicking, repairing and touch-up etc. operations.
- 4 Wiping tip on high sulphur content sponge, dirty or dry sponge and/or rags.
- 5 Contacting with organics, plastic resins, silicone grease, and other chemicals.
- 6 Impurities in solder and/or low tin content.

## Care of Tips

*Important: Remove the tip and clean after every use of at least once a week, remove any loose build up in the barrel or tip to prevent tip seizing.*

- The tips supplied are iron plated copper and if used properly will last a long time.
- 1 Always keep tip tinned before returning the iron to the holder prior to switching off or storing for any period of time, wipe only before using.
  - 2 Don't keep iron set at high temperatures for long period as this will break down the surface plating of the tip.
  - 3 Don't use excessive pressure on a tip or rub a tip on a joint during the making of a joint as it does not improve heat transfer and damages the tip.
  - 4 Never clean tip with abrasive materials or files.
  - 5 Don't use fluxes containing chloride or acid. Use only rosin or activated rosin fluxes.
  - 6 If any oxide film does form, this can be cleaned by carefully rubbing with a "600-800 grit" emery cloth, or isopropyl alcohol and re-heat. Re-tin the tip using rosin core solder.

## New tip

- Care for the new tip according to the following procedures for longer tip life.
- 1 Set temperature at 250°C, then turn main power switch "on".
  - 2 Flood the tinned surfaces with rosin core solder after reaching 250°C.
  - 3 Set to desired temperature after warming at 250°C for three minutes.
  - 4 The iron is ready for use after reaching the pre-set desired temperature.

## Maintenance

### Tip Replacement and Dressing

- 1 Turn off the iron and disconnect the mains plug from the mains supply.
  - 2 Allow the iron to cool completely before attempting disassembly.
  - 3 Unscrew the knurled nut, and remove the barrel assembly.
- Note: the ceramic heating element may be broken by careless handling.*
- 4 Remove the tip, and blow out any accumulated dust. Avoid getting dust in your eyes.
  - 5 Replace the tip and screw back the retaining knurled nut and barrel assembly using only firm hand pressure to tighten. *Do not use pliers.*

### Filter Replacement

Under normal operating conditions the filter should be replaced once a month or when excessive dust has obviously adhered to or discoloured the filter. Failure to change the filter regularly will directly affect the absorption capacity and effectiveness of the fume extractor. Follow the directions on the back page to replace the filter.

**Replacement filter part number: T 1291**

## General Cleaning

The outer case of iron or station may be cleaned with a damp cloth using small amounts of liquid detergent. Never douse the unit in liquid or allow any to enter the case of the station. Never use any solvent to clean the case.

## WARNING

- THE APPLIANCE IS NOT INTENDED FOR USE BY YOUNG CHILDREN OR INFIRM PERSONS WITHOUT SUPERVISION.
- YOUNG CHILDREN SHOULD BE SUPERVISED TO ENSURE THAT THEY DO NOT PLAY WITH THE APPLIANCE.
- THE SOLDERING IRON MUST BE PLACED ON ITS STAND WHEN NOT IN USE.