



PROFESSIONAL AUDIO PRODUCTS

Evacuation Controller A 2075



DESCRIPTION

The safety of commercial and public buildings and their occupants is a very real issue these days. This simple, easy to install and use controller is designed to alert the occupants of a building that there is some form of emergency. This emergency could be in the form of a fire, gas leak, bomb scare, earthquake, etc. There are two modes of operation, Auto or Manual, plus Isolate which are selected via the front panel key switch.

Auto Position

When selected to the auto position the panel will respond to any signal received at the buildings Fire Indicator Board (FIB). This signal then activates the alert tone. If after a pre-set time this condition has not been attended to, the panel will change to the evacuation mode. The evacuation tone will continue to sound until the panel has been reset. In the auto position the front panel alert, evac and cancel controls are inoperative. All other functions will work, ie. paging, bell chime and BGM.

Manual Position

In the manual position any of the functions may be initiated from the controls on the front panel, i.e. Alert, Evac, or PA. This allows the operator to select either of these functions as required.

Other Functions:

The unit includes an auxiliary input with a volume control mounted on the front panel. Further to this, provision has been made for a BGM source to be played through the controller. AUX & BGM inputs are automatically muted when any other function is operated. A microphone input has been included on the front panel. This can be used for either general or emergency paging. Paging over-rides all other functions. A pre-announcement chime is available on the microphone input. This can be switched on or off internally as required. Included is a unique tone or bell chime for signalling lunch breaks, start of class etc. This can be operated from the front panel or via contacts on the rear panel for remote activation ie. by a time clock or remote switch.

FEATURES

- Stand alone control unit.
- Standard 1 unit 19" rack cabinet
- Interfaces with Fire Indicator Boards
- Remote operation of Alert and Evac tones
- 240V mains and 24V DC operation
- Auto / Manual / Isolate key switch
- Key switch keyed to 003 standard
- Local operation of Alert, Evac, PA
- Provision for voice over message (A 2076)
- Microphone socket for PA use
- Provision for BGM
- Bell chime facility
- Auxiliary Input
- Australian Made
- Switched 24V output for operating over-ride relay on remote volume controls
- On-board timer for remote alert activation adjustable from 30 seconds to 7.5 min in 30 second increments
- Externally operated inputs are activated by switching to ground
- Auxiliary level output
- Suitable for any amplifier with an aux input
- Can be used as a standard PA system
- Separate relay outputs for Alert & Evac functions
- Remote cancel facility
- Tones conform to relevant Australian standard

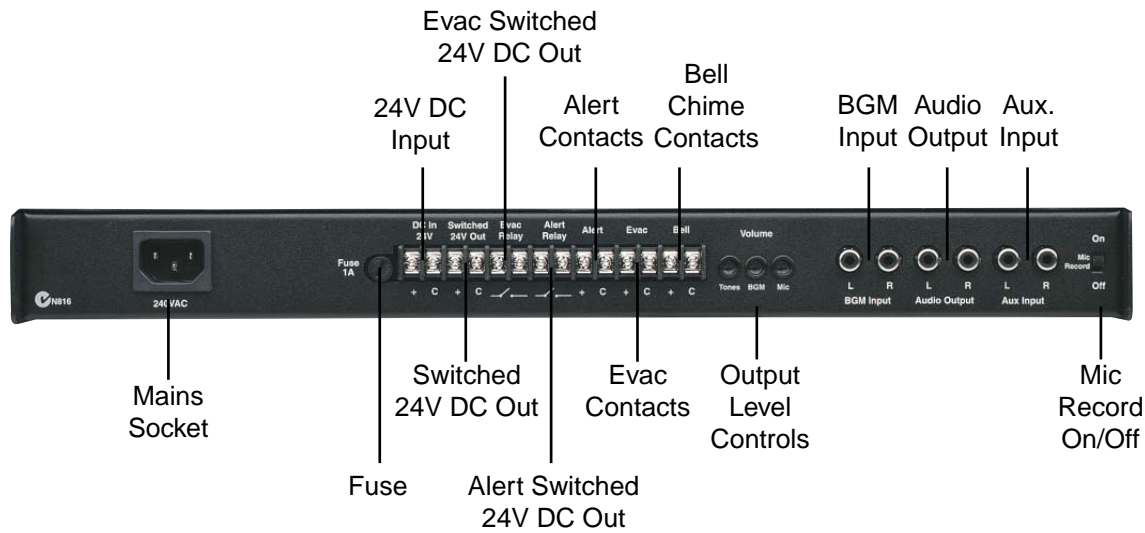

OPTIONAL EXTRAS

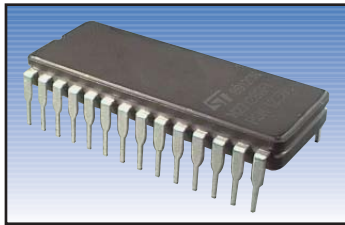

A 2076: When fitted the voice over chip will interrupt the evacuation tone after four cycles and deliver its recorded message twice. This sequence continues until the evac tone is manually cancelled. Message length is approximately 16 seconds.



A 2074: Allows the A 2075 alert/evac unit to be controlled remotely. Featuring alert, evacuation, bell and cancel button. Maximum cable length 100m. Simply connects to main A 2075 unit via suitable 9 core cable.

SPECIFICATIONS*

Output level:0dBm
Distortion:0.01%
Frequency response:140Hz - 20kHz
SIGNAL TO NOISE RATIO
Aux/music input:-90dB typically
Alert/evac/chime:-70dB typically
INPUT SENSITIVITY
Mic:2mV balanced
Aux inputs:300mV unbalanced
OUTPUT CONNECTORS
Audio output:RCA stereo socket
Switched 24V DC out:Screw terminals
INPUT CONNECTORS
Mic:5 pin XLR
Aux inputs:RCA stereo socket
24V DC power:Screw terminals
240V AC power:IEC chassis socket
Remote contacts:Screw terminals
Muting:PTT via microphone
 Switch contacts

CONTROLS

Mic input:Rear volume
BGM input:Rear volume
Aux input:Front volume
Tones & chime:Rear volume
Power:On/off switch
Mode selection: 003 keyswitch
Alert switch:Illuminated switch
Evac switch:Illuminated switch
Bell / chime switch:Illuminated switch
Indicators:Power on LED

Power supply:240V AC or 24V DC
Dimensions:≈483W x 152D x 44H
Protection:1A fuse
Weight:≈2.5 kg
Colour:Black

* Specifications subject to change without notice.

Distributed By: